







Ravaglioli

COMPANY WITH
QUALITY SYSTEM
CERTIFIED BY DNV GL
= ISO 9001 =

- EQUILIBRATRICI AUTOCARRO 
- TRUCK WHEEL BALANCERS 
- LKW - RADAUSWUCHTMASCHINEN 
- EQUILIBREUSES POIDS LOURDS 
- EQUILIBRADORAS DE CAMIONES 

GTL4.
GPTL4.

140RC
140R

GTL3.
124RCD

124RD

GT2.
GTL2.

120RC
120R

NEW MODELS WITH
WHEEL AIR LOCKING



SINCE 1958



HEAVY INDUSTRIAL USAGE

24 volt motor with low speed rotation = min. power consumption





GTL4.140RC
GTL4.140R

TFT SVGA 19"



200 kg

Sollevamento pneumatico.
Pneumatic lift.
Luftheber.
Levage pneus.
Elevador neumático.

**GTL4.140 - GPTL4.140 - GTL3.124
AUTOMATIC DISTANCE +
DIAMETER MEASUREMENT**



Calibro digitale con lettore ottico, con asta in alluminio su boccole. Acquisizione automatica della distanza e del diametro fino a 26".

Digital calliper with optical sensor, with alloy shaft sliding on bushes. Automatic storage of distance and diameter up to 26".

Digitaler mit optischer Ablesevorrichtung versehener Abstandstaster mit Alustange auf Buchse für die automatische Übernahme von Abstand und Durchmesser bis zu 26".

Pige numérique munie de lecteur optique, avec tige en aluminium sur bagues. Enregistrement automatique de la distance et du diamètre jusqu'à 26".

Calibre digital con lector óptico y con eje de aluminio apoyado sobre cojinetes. Medición automática de la distancia y del diámetro hasta 26".



**GTL4.140 - GPTL4.140 - GTL3.124
DOUBLE WHEEL STOP + LOCK IN POSITION**

Rapidità d'uso: avviamento automatico con l'abbassamento del carter e arresto automatico nella posizione di squilibrio esterno. Un freno elettro-pneumatico mantiene la ruota in posizione. Riposizionamento automatico nella posizione di squilibrio interno.

Quick balancing: automatic start when the cover is lowered and automatic stop in the external unbalanced position.

An electro-pneumatic brake holds the wheel in position.

Automatic rotation to the internal unbalance position.

Schnell einsatzbereit dank dem automatischen Programmablauf und der automatischen Arretierung in Position des äusseren Ausgleichsgewichtes.

Eine elektro-pneumatische Bremse hält das Rad in Position. Automatische Positionierung auf Unwucht innen.

Usage rapide: lancement automatique à la descente du carter et arrêt automatique en position de balourd extérieur.

Un frein électro-pneumatique maintient la roue dans sa position.

Repositionnement automatique dans la position du balourd intérieur.

Rapidez de uso: arranque automático al bajar la protección de rueda y bloqueo automático en la posición de desequilibrio exterior.

Un freno electro-neumático mantiene la rueda en posición.

Reposicionamiento automatico en la posición del desequilibrio interno.

GPTL4.140RC
GPTL4.140R

AIR LOCK

TFT SVGA 19"

Modello con bloccaggio ruota pneumatico.

Model with pneumatic locking of the wheel.

Ausführung mit Pneumatischer Arretierung.

Version avec blocage pneumatique de la roue.

Versión con bloqueo neumático rueda.



HANDS FREE
AIR LOCK CONTROL



Gestione guidata dell'equilibratura - Comandi logici interattivi con tasti multifunzione: le funzioni dei tasti variano a seconda dell'uso, e sono identificate sul display da icone grafiche di immediata comprensione

Guided balancing procedure. Interactive inputs with multifunction keys: the functions related to each key vary according to use and are identified on the display by graphic icons for immediate understanding.

SW-geführter Wuchtvorgang. Steuerbefehle logisch gekoppelt mit Multifunktionstasten: die Tastfunktionen ändern sich je nach Gebrauch, sind am Display mittels grafischer Abbildungen dargestellt und sind dadurch leicht verständlich.

Gestion assistée de l'équilibrage. Commandes logiques interactives avec touches multifonctions: les fonctions des touches varient selon l'usage et sont identifiées sur l'écran par des icônes immédiatement compréhensibles.

Gestión guiada del equilibrado. Mandos lógicos interactivos con teclas multi-funciones: las funciones de las teclas varían según el uso, y son identificadas en la pantalla por medio de iconos gráficos de fácil comprensión.



GTL3.124RCD
 GTL3.124RD

DIGITAL



200 kg



GTL2.120RC
 GTL2.120R

LCD DISPLAY



200 kg



132 x 40 mm

Display grafico LCD retroilluminato.

Backlit graphic LCD display.

Graphischer LCD-Display mit Hintergrundbeleuchtung.

Écran graphique LCD retro-éclairé.

Pantalla gráfica LCD con iluminación trasera.



Un freno elettro-pneumatico mantiene la ruota in posizione.

An electro-pneumatic brake holds the wheel in position.

Eine elektro-pneumatische Bremse hält das Rad in Position.

Un frein électro-pneumatique maintient la roue dans sa position.

Un freno electro-neumático mantiene la rueda en posición.

STANDARD



CALIBRATION KIT

GTL4.140RC
 GTL3.124RCD
 GTL2.120RC
 GT2.120RC

RC-RCD

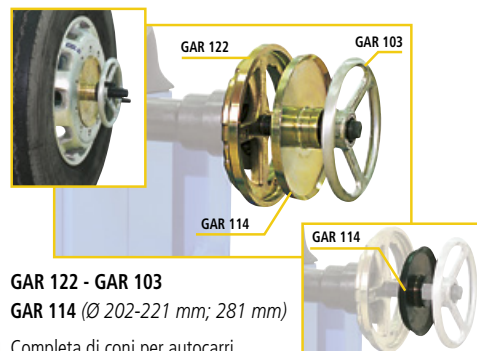

GAR 122 - GAR 103
 GAR 114 (Ø 202-221 mm; 281 mm)

Completa di conici per autocarri
 Complete with cones for trucks
 Komplett mit Spannzubehör für LKW
 Équipée de cônes PL.
 Completa de conos para camiones

GTL4.140R
 GTL3.124RD
 GTL2.120R
 GT2.120R

R-RD

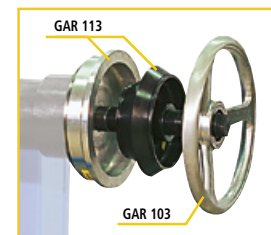

GAR 113 (Ø 118-174 mm) - GAR 103

Completa di conici per autocarri leggeri.
 Complete with cones for light trucks.
 Komplett mit Spannzubehör für LLKW.
 Équipée de cône pour poids lourds légers.
 Completa de conos para camiones ligeros.

OPTIONS - TRUCK

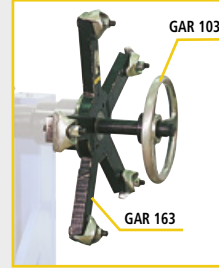
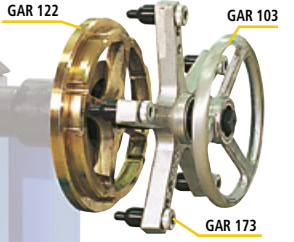

GAR 171 (3 x 170, 186, 205, 222, 245)
GAR 172 (4 x 275, 285)
GAR 173 (5 x 225, 286, 335)

GAR 172

GAR 124
 Distanziale per GAR122
 Spacer for GAR122
 Distanzstück für GAR122
 Entretoise pour GAR 122
 Espesor para GAR122

GAR 161 22,5"-18"
 FISCHER (Europa)
GAR 162 20"-28"
 DAYTON (USA)
GAR 163 24"-28"
 DAYTON (USA)

GAR 344
 Bloccaggio rapido
 Quick locking
 Schnellspannung
 Blocage rapide
 Bloqueo rapido

GAR 266T (→ GTL4 - GPTL4)
GAR 266T/S (→ GTL3)
3D SENSOR

Tastatore per la misurazione automatica della larghezza del cerchio.

Calliper for automatic measurement of rim width.

Automatischer Felgenbreitentaster.
 Pige automatique de la largeur de la jante.

Palpador para la medición automática de la anchura de la llanta.



GAR 214TK (→ GTL4 - GPTL4)
SONAR RUN OUT

Dispositivo di misura elettronica dell'eccentricità (richiesto GAR 266T-T/S)

Electronic device for run-out measurement (to be used with GAR 266T-T/S)

Vorrichtung zur Vermessung der Radunrundheit (Verwendbar nur mit GAR 266T-T/S)

Dispositif de mesure électronique de l'excentricité (utilisable seulement avec GAR 266T-T/S)

Lector de excentricidad rueda (solamente con GAR 266T-T/S)

OPTIONS - CAR



GAR 111
 (Ø 44-112 mm)
 Auto
 Car
 Pkw
 Voiture
 Turismos



GAR 104
 Ghiera auto
 Clamp for cars
 Pkw-Spannmutter
 Ecrou VL
 Garra auto

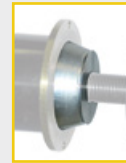

GAR 112
 (Ø 95-132 mm)
 Fuoristrada
 Off-road vehicles
 Geländewagen
 Véhicules tout-terrain
 Todo terrenos

BALANCER DIMENSIONS

GTL4

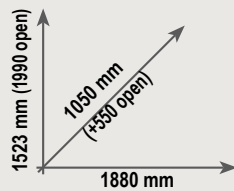

GTL3

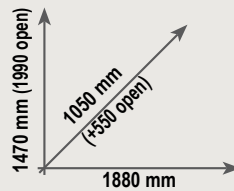

GTL2

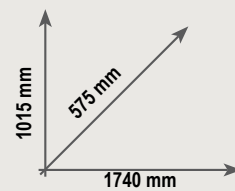

DATI TECNICI	TECHNICAL DATA	TECHNISCHE DATEN	DONNEES TECHNIQUES	DATOS TÉCNICOS	
Diámetro cerchio	Rim diameter	Felgendurchmesser	Diamètre de la jante	Diámetro de la llanta	10" - 26" automatic 10" - 30"
Larghezza cerchio	Rim width	Felgenbreite	Largeur de la jante	Anchura de la llanta	1.5" - 22"
Peso max ruota	Max wheel weight	Maximales Radgewicht	Poids maxi de la roue	Peso máximo de la rueda	200 kg
Precisione equilibratura	Read-out accuracy	Auswuchtgenauigkeit	Précision d'équilibrage	Precisión de equilibrado	10 g 1g
Velocità di rotazione (giri/min)	Rotation speed (rpm)	Drehgeschwindigkeit (Umdr/min)	Vitesse de rotation - tours/min	Velocidad de rotación vueltas/min.	80 100
Alimentazione	Power supply	Stromversorgung	Alimentation	Motor monofásico	230 V 50-60Hz / 1ph



Ravaglioli S.p.A.
 via 1° maggio 3
 Fraz. Pontecchio M.
 40037 Sasso Marconi (Bo) - Italia
 Tel. +39 - 051 - 6781511
 Fax +39 - 051 - 846349
 rav@ravaglioli.com
 www.ravaglioli.com

RAV France
 4, Rue Longue Raie
 ZAC de la Tremblaie
 91220 Le Plessis Pâté
 Tel. 01.60.86.88.16
 Fax 01.60.86.82.04
 rav@ravfrance.fr

Ravaglioli Deutschland
 Kirchenpoint 22
 85354 Freising
 Tel. 08165-646956
 Fax 08165-646958
 info@ravaglioli.de

RAV Equipment UK LTD
 Prince Albert House
 20 King Street
 Maidenhead, SL6 1DT
 Tel. +39 - 0516781522
 rav@ravaglioli.com

RAV en Belgique
 Nederlandstalig
 Tel. 0498-162016
 Fax 016-781025
 Zone Francophone
 Tel. 0498-163016
 Fax 078 055030

RAV Equipos España S.L.U.
 Avenida Europa 17
 Pol. Ind. de Constanti
 Tarragona 43120
 Tel. 977 524525
 Fax 977 524532
 ravequipos@ravaglioli.e.telefonica.net



DRJ06U(8)

Le caratteristiche tecniche e gli allestimenti presentati in questo prospetto possono subire variazioni. Le immagini riprodotte non sono vincolanti.
 Technical data and composition presented in this catalogue may vary. Pictures reproduced are only indicative.
 Die techn. Daten und die Ausrüstungen, die in diesem Prospekt enthalten sind, können Änderungen erfahren. Deshalb sind die Abbildungen unverbindlich.
 Les caractéristiques techniques et les compositions présentées dans ce prospectus peuvent subir des variations. Les images reproduites n'ont qu'une valeur indicative.
 Las características técnicas y las composiciones ilustradas en este folleto pueden sufrir variaciones. Las imágenes propuestas son solamente indicativas.

